

GÜDEL



Idea about this presentation is to give you snapshots about GÜDEL India in
Tire world



GÜDEL

Gudel India



Anywhere around the globe successful companies optimize their production and logistics processes and enhance their productivity. Gudel makes its contribution with know-how, experience and technology.

- **Year of Foundation : 2004**
- **70+ Employees**
- In house Design, Manufacturing & Assembly Facility
- ISO 9001 :2004 Certified .
- Preferred Brand in India.

Idea > Leadership

GÜDEL



End of line Palletizing systems

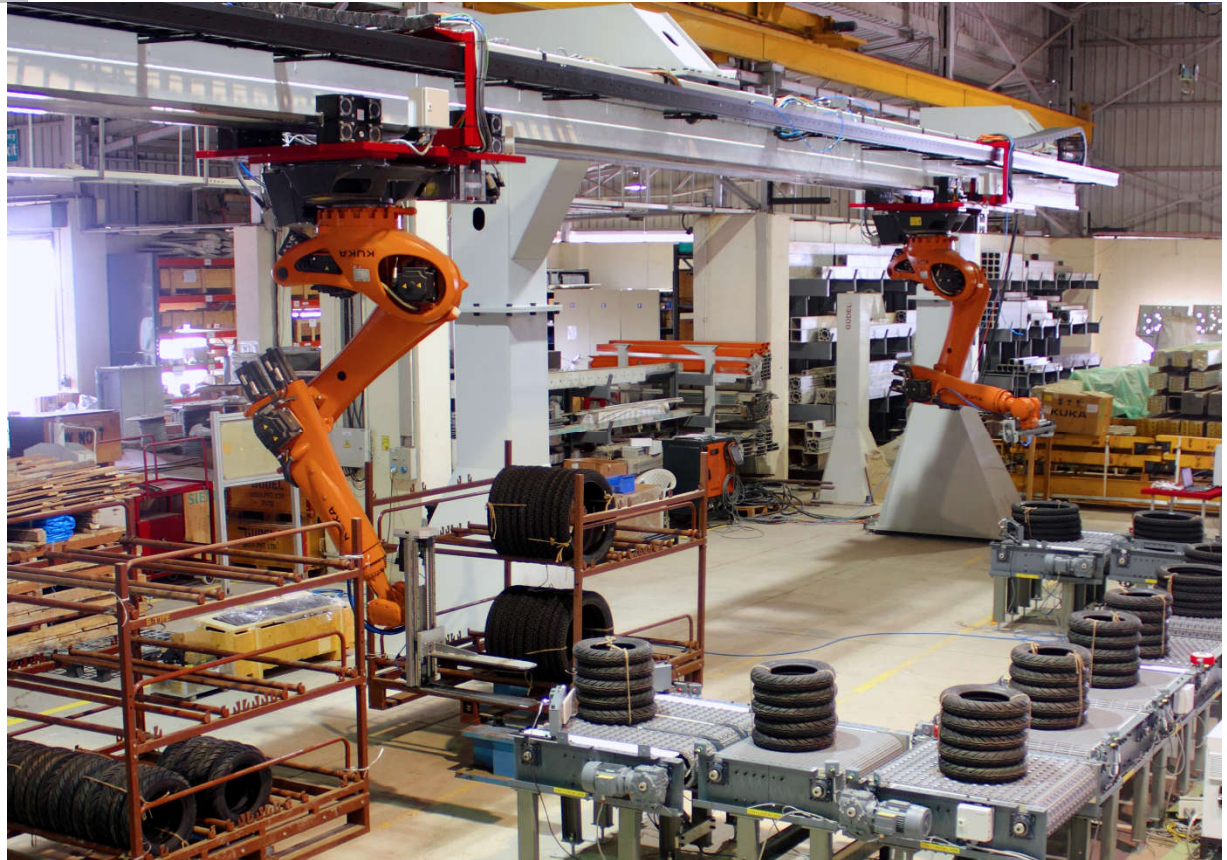

Gantry Systems for sorting

PCR

TBR

Motor cycle &
Scooter Tires

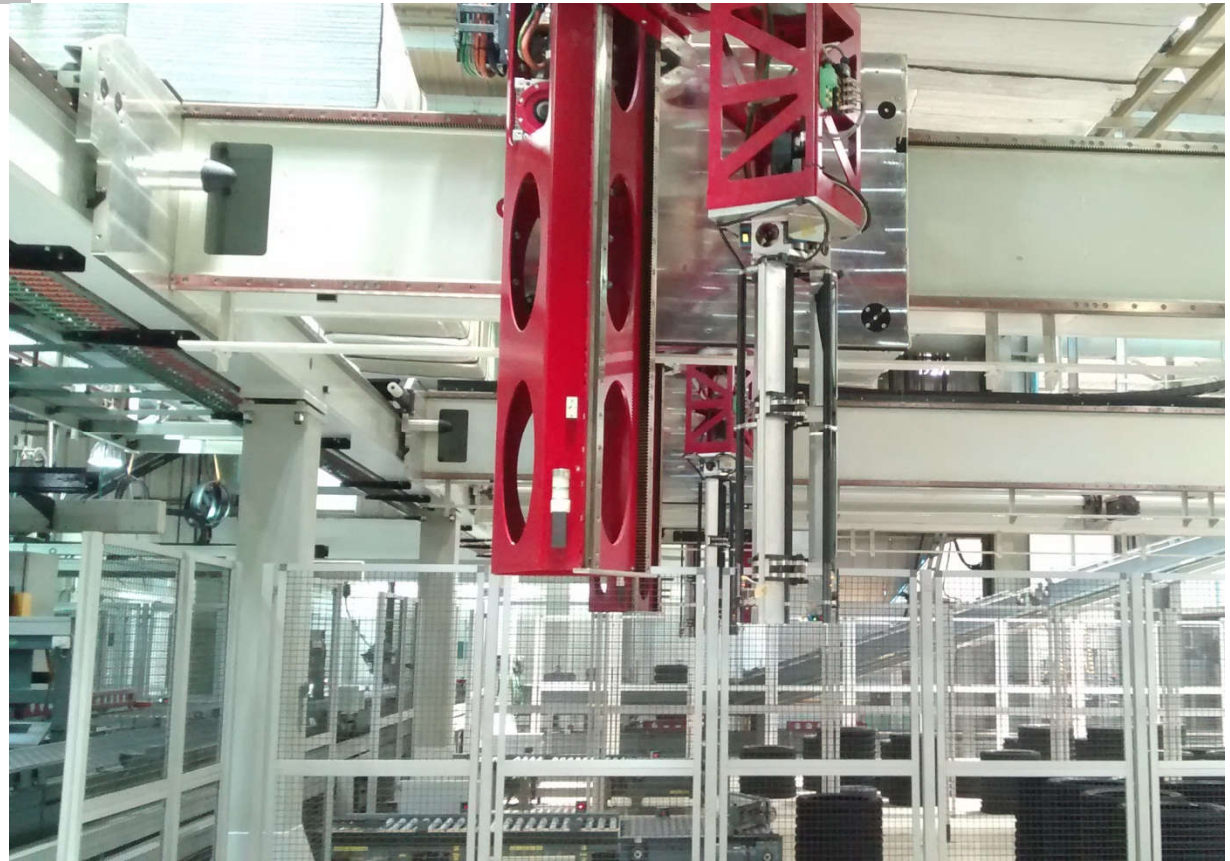

GÜDEL

Conveying Systems:

TRT conveyors

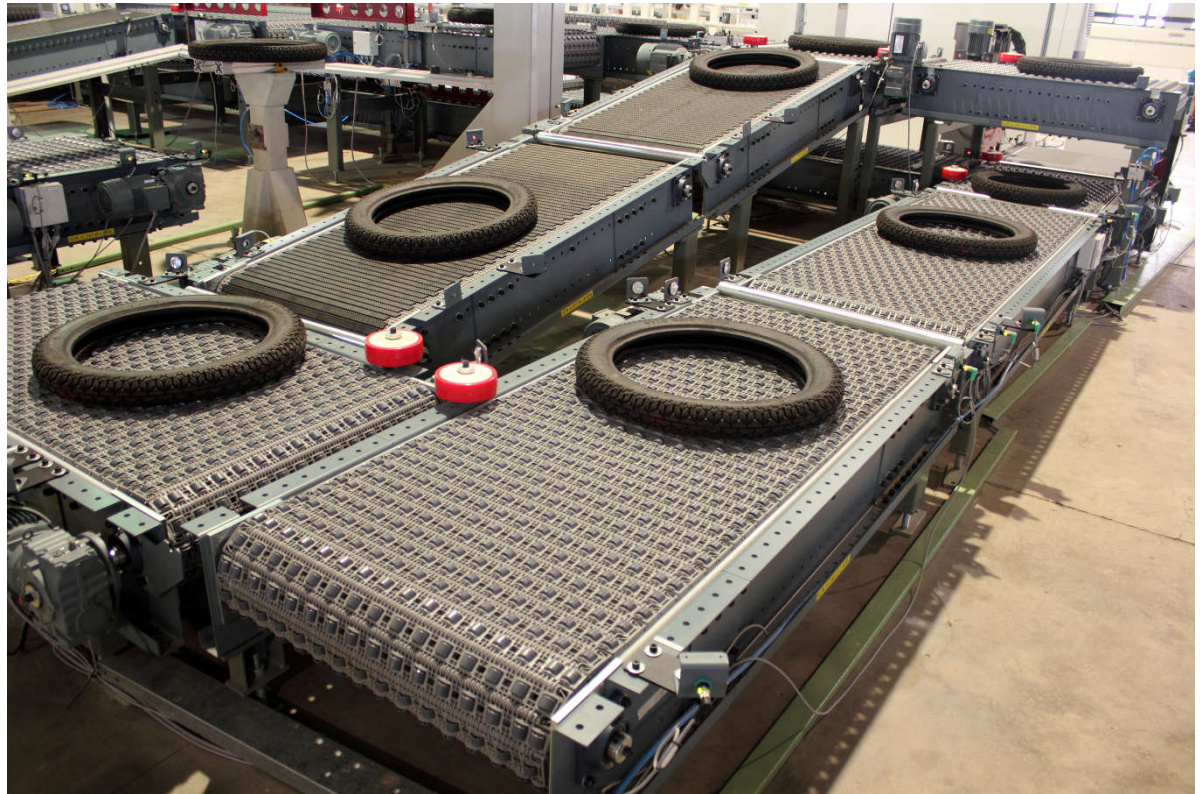

GÜDEL

Conveying:

Belt conveyors

Roller conveyors

Continuous lifters



Conveying:
Belt conveyors
Roller conveyors
Continuous lifters

GÜDEL



GÜDEL

Conveying:

Belt conveyors

Roller conveyors

Continuous lifters

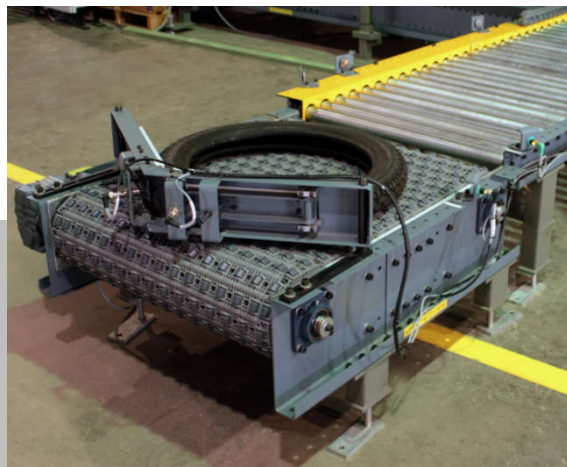
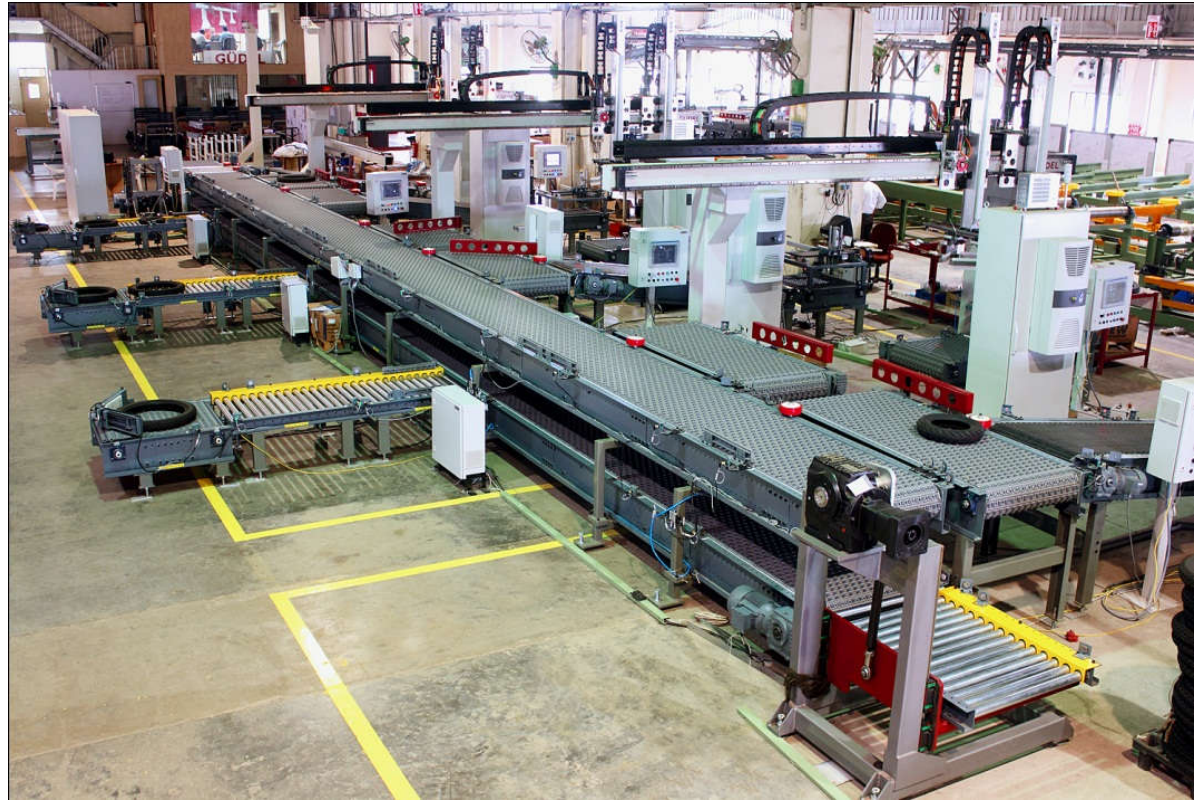

GÜDEL

Conveying:

Belt conveyors

Roller conveyors

Continuous lifters



GÜDEL

Conveying:

Roller conveyors &
Other equipment's



GÜDEL

Special
conveying
systems

Skid handling

Calendar role
handling



Gantry Systems for balancing machines

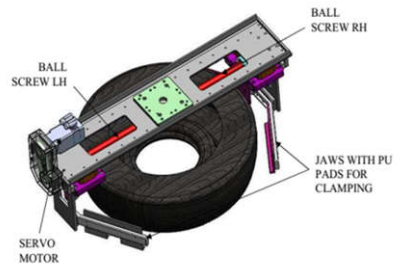

GÜDEL

Robotic
Palletizing

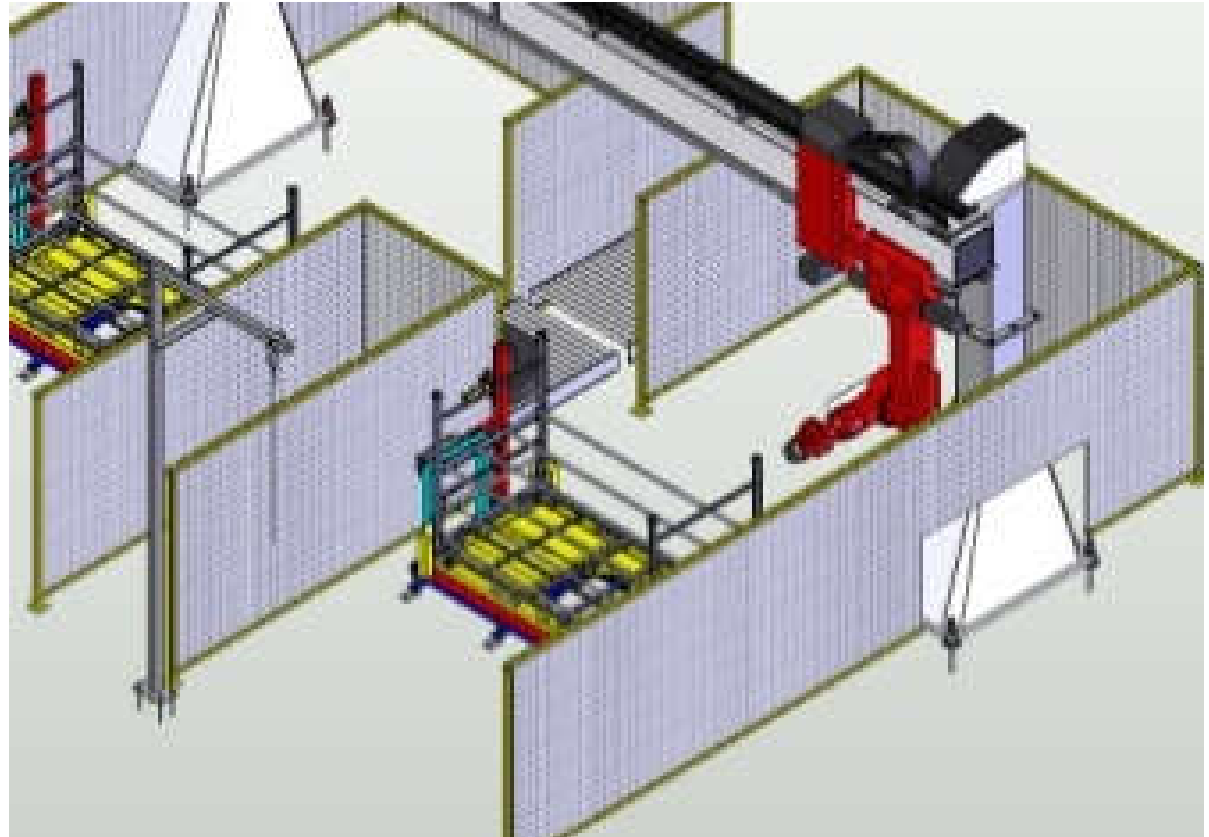

GÜDEL

Sorting and
Conveying



GÜDEL



Control Systems
including WMS

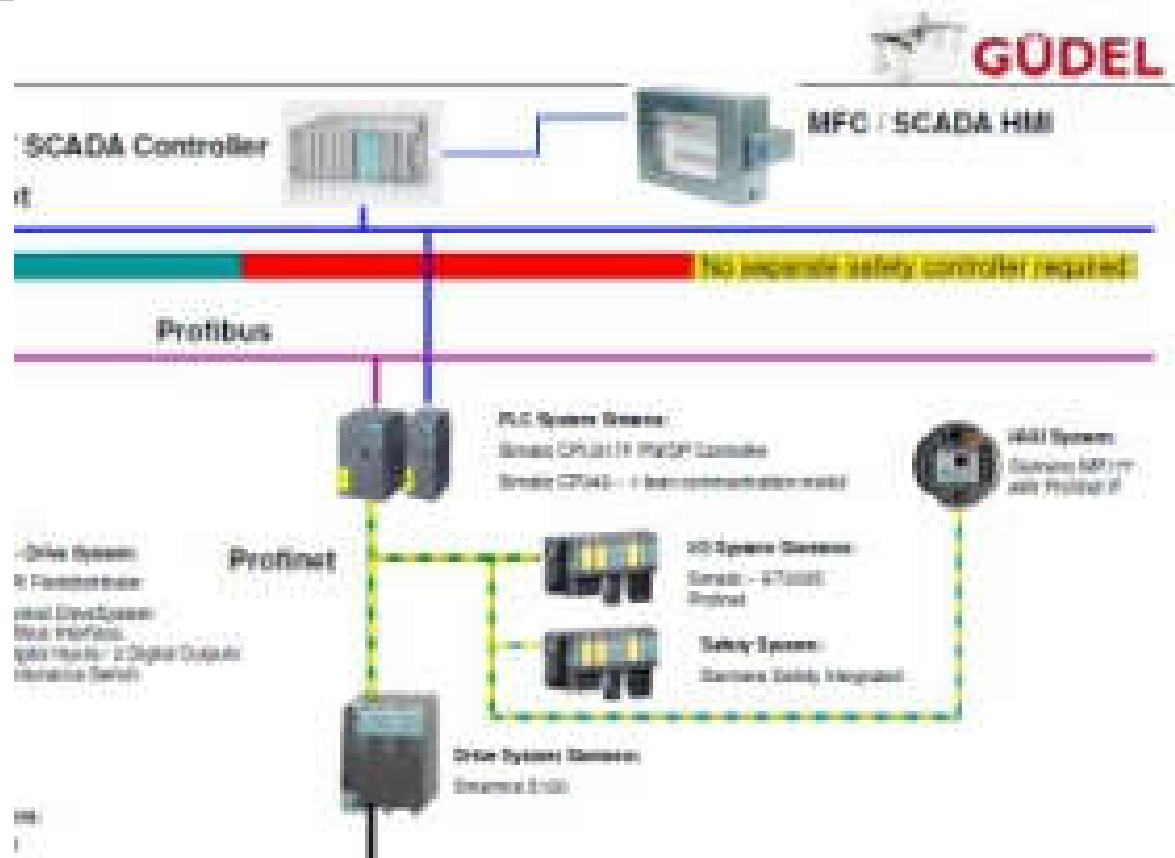

Various Auxiliary Systems

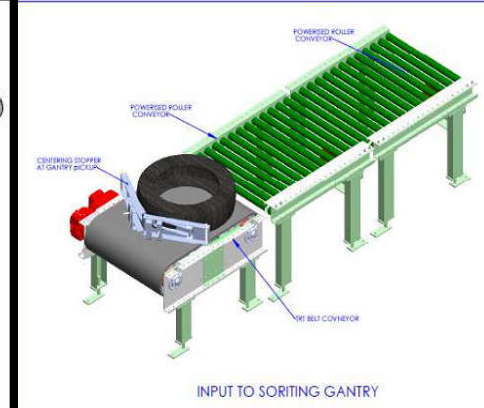
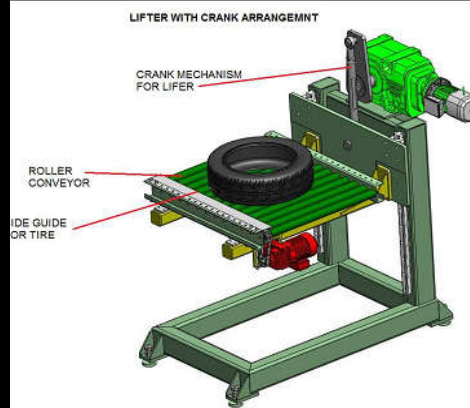
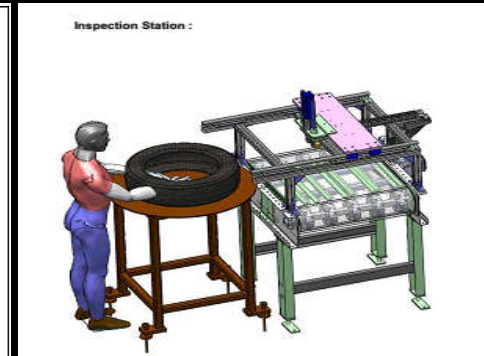
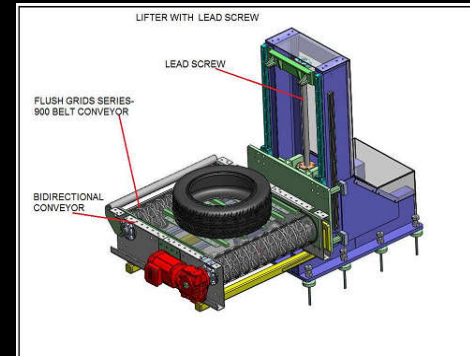

GÜDEL

New developed ink marking systems instead of Thermal Process.

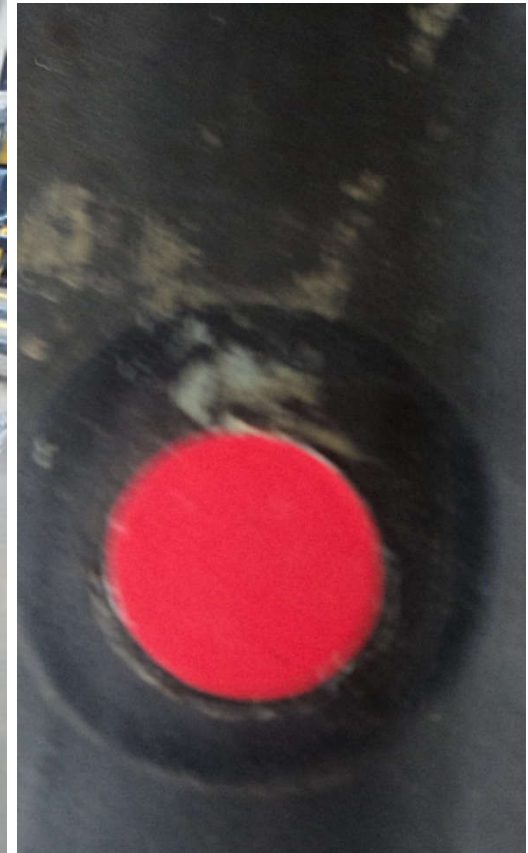

Together we can



GÜDEL

- Green tire handling using Gantry systems.
- Curing press feeding through Gantry.
- Trench conveyors.
- Transfer conveyors from Curing to Inspection.
- Auxiliary equipment like Centering unit, Diverter, lifter, Singulation unit Etc
- Finished Tire Sorting & Stacking
- Finished Tire Palletization.
- FIFO Conveyor for Raw material
- Tire traceability using sensors, barcode readers & high end control system.

Projects Executed



GÜDEL

- **MRF India:**

1. LMC Tyre Sorting & Palletizing Automation
2. Curing Line conveyor system for LMC Tyres
3. Calendar Role handling Roller conveyors

- **Bridgestone India:**

- PCR Tyre Balancing Line conveyor system
- PCR Balancing out conveyor system
- Gum Rework conveyor
- TBR Tyre OE & Replacement conveyor system
- Uniformity Line conveyor
- GT Handling system

- **CEAT India :**

- TBR Tyre GT Handling gantry system.

Worldwide Installation



Tire Projects 2010-2014

Greentire

- Bridgestone US AS/RS Push back Storage
- Bridgestone US AS/RS Storage
- Pirelli Settimo Italy AS/RS Storage & Press handling
- Pirelli Settimo Italy Linear axis for Tire building machine
- Michelin France Linear axis for Tire building machine
- Goodyear US Linear axis for Tire building machine
- Goodyear Germany gantry/Robot for GT picking
- Goodyear Germany AGV (automated guided vehicle)
- Goodyear Germany AS/RS and Storage

Finishing tire

- Pirelli Settimo Italy gantries for sorting
- Pirelli Höchst Germany gantries for sorting
- Pirelli Höchst Germany Robodflex & Gantry for Palletizing
- Pirelli Höchst Germany Conveyor system
- Pirelli UK gantries for sorting
- Pirelli UK Robot for Palletizing
- Pirelli UK Conveyor system

Worldwide Installation



Finishing tire

- MRF Indian gantries for sorting
- MRF Indian Robodflex for Palletizing
- MRF Indian Conveyor system
- Bridgestone SC US gantries for sorting
- Bridgestone SC US Gantry for Palletizing
- Bridgestone SC US Conveyor system
- Bridgestone Spain Gantry for sorting
- Bridgestone Spain Robot for Palletizing
- Bridgestone Spain Conveyor system
- Continental France Palletizing system
- Continental France Conveyor system
- Continental Czech Republic Palletizing system

Worldwide Installation



Finishing tire

- MRF Indian gantries for sorting
- MRF Indian Robodflex for Palletizing
- MRF Indian Conveyor system
- Bridgestone SC US gantries for sorting
- Bridgestone SC US Gantry for Palletizing
- Bridgestone SC US Conveyor system
- Bridgestone Spain Gantry for sorting
- Bridgestone Spain Robot for Palletizing
- Bridgestone Spain Conveyor system
- Continental France Palletizing system
- Continental France Conveyor system
- Continental Czech Republic Palletizing system

Go Gudel!

Thank you.

Raw material
and component
processing

Green tire
processing

Green tire
storage

Curing

Testing

Sorting

End-of-line
palletising

Warehouse

Shipment

Idea > Leadership